

## Type WM603 Load Cell

### Weighing modules



#### Features

---

- Weighing range: 10t...30t
- Use high-quality sensors with high weighing accuracy
- Unique structure, can be easily installed on various tanks
- Support bolts to prevent equipment from tipping over
- High-quality alloy steel, nickel-plated surface
- Simple and fast installation
- Easy maintenance, saving downtime maintenance time
- Protection grade IP67/IP68

#### Applications

---

- Hopper, silo
- Platform, vertical tank
- Ingredient weighing of tank
- Weighing control during production process

## Weighing modules

### Description

WM603 static load weighing module uses high-quality sensor elements. Its characteristics are compact structure, no need to install other accessories, and the self-stabilizing sensor pressure head makes the measurement accurate and repeatable. Made of alloy steel, stainless steel is optional, suitable for weighing control of tank batching process in harsh environments. Quick installation, saving installation and downtime maintenance time. Static load weighing module can be easily installed on containers of various shapes, and can be easily loaded, batched or stirred in the container.

## Weighing modules

### Available Models

P/N	Capacity	Accuracy	Full Article Description
7220899911-00	10t	C3	WM603-10t-C3-10t-12B-2-FH
7220899911-01	20t	C3	WM603-20t-C3-20t-12B-2-FH
7220899911-02	30t	C3	WM603-30t-C3-30t-12B-2-FH



## Type WM603 Load Cell

### Technical Specifications WM603

Accuracy Class		OIML R60 C3
Output Sensitivity ( = FS )	mV/V	2.0 ± 0.002
Maximum Capacity ( Emax )	kg	10t,20t,30t
Max. Number of Load Cell Intervals	n/c	3000
Ratio of min. LC Verification Interval	Y = Emax / vmin	7500
Combined Error	%FS	≤± 0.02
Creep Error (30 minutes)	%FS	≤± 0.02
Temperature Effect on Zero (ZTC)	%FS/10°C	≤± 0.02
Temperature Effect on Sensitivity (STC)	%FS/10°C	≤± 0.02
Zero Balance	%FS	≤± 1.5
Safe Overload	%FS	150
Ultimate Overload	%FS	300
Excitation, Recommended Voltage	V	5 ~ 12
Excitation, Maximum Voltage	V	18
Input Resistance	Ω	760 ± 20
Output Resistance	Ω	700 ± 4
Insulation Resistance (50V)	MΩ	≥5000
Compensated Temperature	°C	-10 ~ + 40
Operating Temperature	°C	-35 ~ + 65
Storage Temperature	°C	-40 ~ + 70
Load Cell Weight	kg	
Element Material		Alloy steel/ Stainless steel
Ingress Protection (acc. to EN 60529)		IP68
Recommended Torque on Fixation Bolts	Nm	1100
ATEX Classification (optional)		II 1G Ex ia IIC T4 Ga II 1D Ex ia IIIC T 200 135°C Da II 3G Ex ic IIC T4 Gc

### Wiring

#### Features:

Cable type: Shielded, 4 conductor cable , conductor AWG 24  
Cable diameter: Ø 5.5mm  
Cable length: 10m (standard), 16m & 20m lengths also available  
Cable jacket: PVC  
Shield not connected to element

#### Mode of Connection

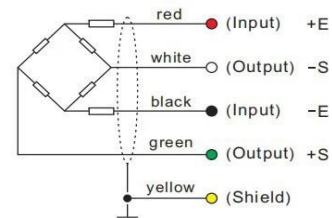

## Type WM603 Load Cell

Dimensions in mm

### Dimensions(mm)

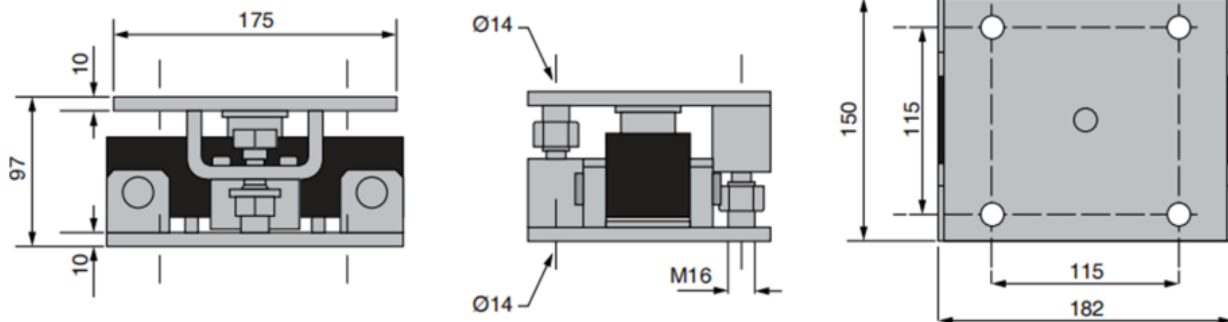

### Specifications

Load Cell		DSB
Rated Load	t	10, 20, 30
Rated Output	mV/V	2±0.0050
Safe overload	%R.C.	150
Ultimate overload	%R.C.	300
Protection class		IP68



**AmCells**™  
AmCells Corp.  
Finest High Tech Load Cell

